

BED

Assembly Manual

KJW.B003

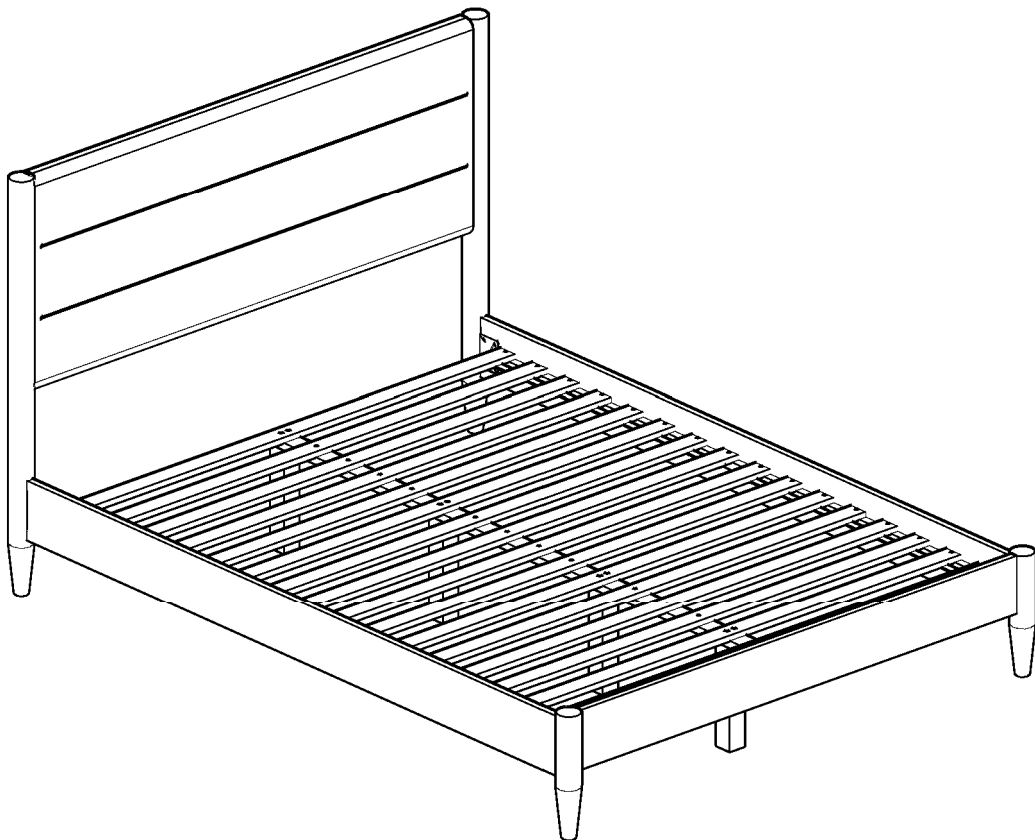

 **CAUTION**

THIS ASSEMBLY MANUAL CONTAINS IMPORTANT SAFETY INFORMATION.

PLEASE READ AND KEEP FOR FUTURE REFERENCE.

ASSEMBLY INSTRUCTIONS

Read these instructions carefully and keep for future reference. Refer to parts inventory for guidance, and ensure you have all pieces before starting.

When assembling, place all parts on a soft, clean, and flat surface such as a carpet to prevent scratches.

! Structural integrity is only guaranteed if all bolts are installed and properly tightened.



TIME

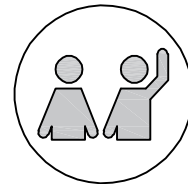

2 OF PEOPLE

!



PLACE THE HEADBOARD AGAINST THE WALL

!

DO NOT DRAG BED, ALWAYS LIFT WITH AT LEAST TWO PEOPLE BEFORE MOVING

<p>1. HEADBOARD ×1</p>	<p>2. HEADBOARD LEG (LEFT) ×1</p>	<p>3. HEADBOARD LEG (RIGHT) ×1</p>
<p>4. FOOTBOARD ×1</p>	<p>5. SIDE RAIL ×2</p>	<p>6. CENTER RAIL ×1</p>
<p>7. CENTER LEG ×4</p>	<p>8. FOOTBOARD LEG (LEFT) ×1</p>	<p>9. FOOTBOARD LEG (RIGHT) ×1</p>

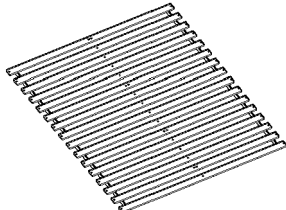
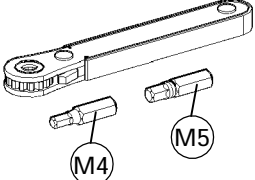
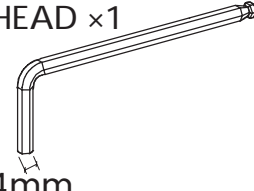
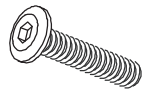
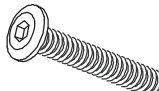
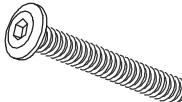
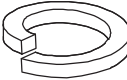
Please read through the instructions below to familiarize yourself with the parts and steps before assembly.

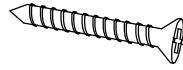
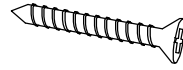
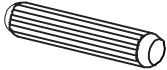
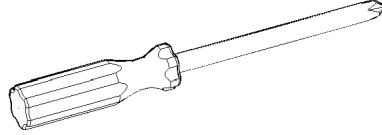
<p>10.SLATS ×8 (2 Set)</p> 	<p>A.RATCHET TOOL ×1</p> 	<p>B.M4 ALLEN KEY LONG BALL HEAD ×1</p>  <p>4mm</p>
<p>C.JCBB BOLT M8 X 35MM ×4</p> 	<p>D.JCBC BOLT M6 X 40MM ×4</p> 	<p>E.JCBC BOLT M6 X 50MM ×8</p> 
<p>F.M8 SPRING WASHER ×4</p> 	<p>G.M8 FLAT WASHER ×4</p> 	<p>H.M6 SPRING WASHER ×4</p> 
<p>I.WOOD SCREW M3.5 X 16MM ×1</p> 	<p>J.WOOD SCREW M4 X 30MM ×44</p> 	<p>K.WOOD DOWEL M8 X 30MM ×4</p> 
<p>Not Included</p>  <p>Phillips Head Screwdriver</p>		

Please read through the instructions below to familiarize yourself with the parts and steps before assembly.

ASSEMBLY INSTRUCTIONS

- 1** Attach headboard leg (left) (2) and headboard leg (right) (3) to the headboard (1), using JCBB Bolt M8 X 35MM (C), M8 Spring Washer (F), M8 Flat Washer (G) and M5 RatchetTool (A). Fully tighten.

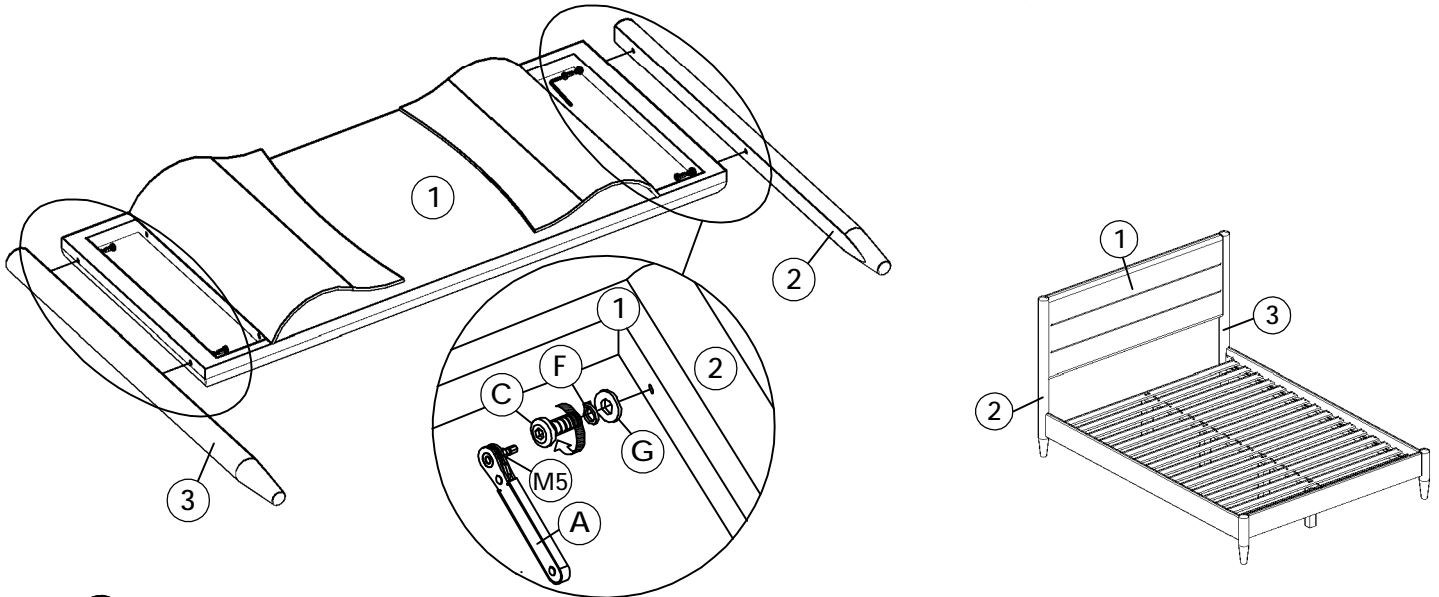

- 2** Attach footboard leg (left) (8) and footboard leg (right) (9) to the footboard (4), using Wood Dowel M8 X 30MM (K), JCBC Bolt M6 X 40MM (D), M6 Spring Washer (H) and M4 Allen Key Long Ball Head (B). Fully tighten.
 Note: Insert the wood dowel(K), then fully tighten the bolts.

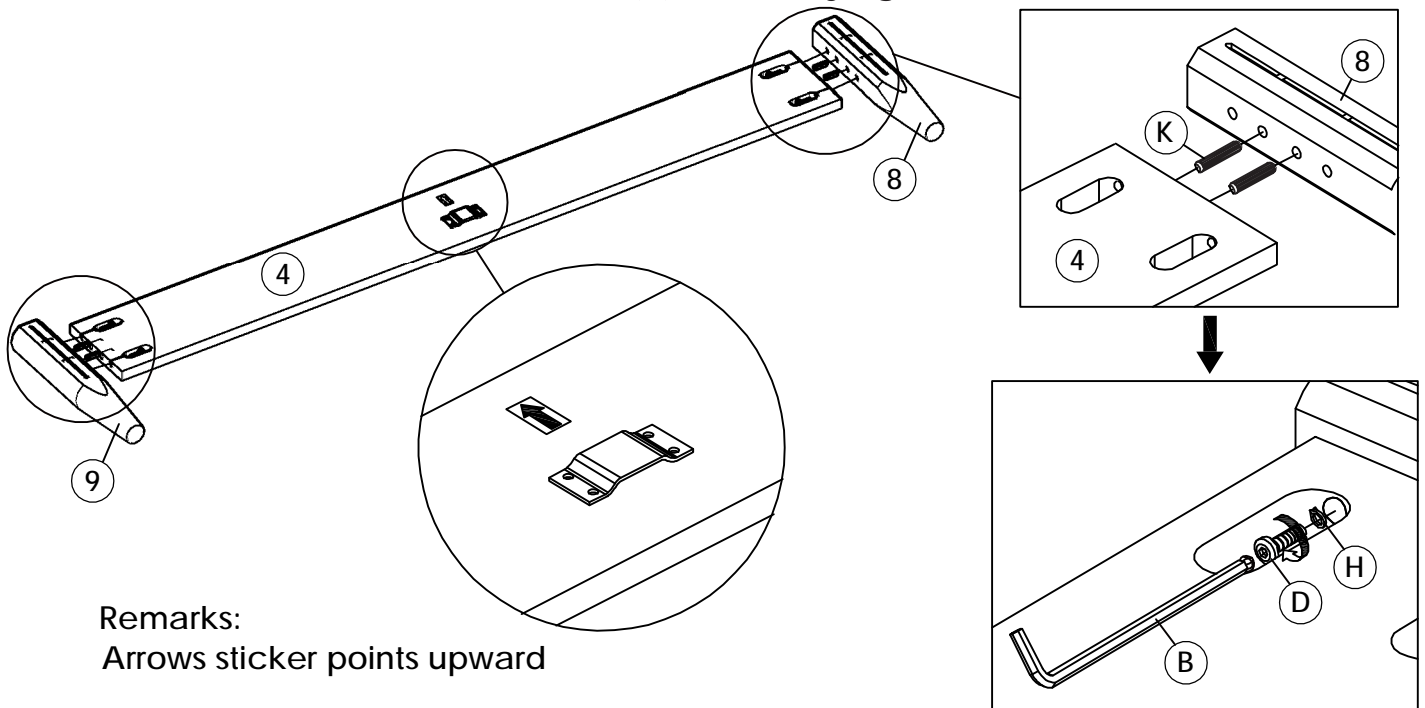

Remarks:
 Arrows sticker points upward

- 3** Attach side rail (5) to headboard leg (left) (2), headboard leg (right) (3), footboard leg (left) (8) and footboard leg (right) (9).
 Note: After slotting in the side rail to the headboard and footboard leg, please push the side rail downward to ensure it is fully slotted in.

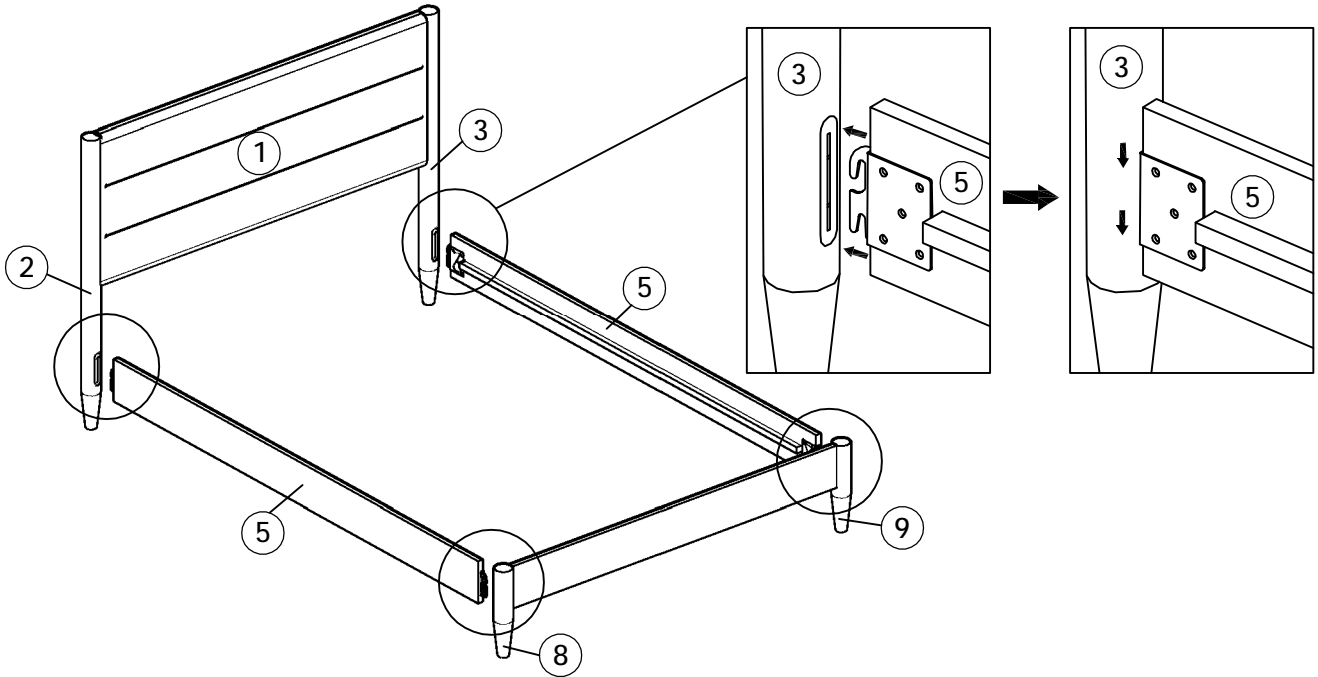

- 4** Attach center leg (7) and slats x8 (2 Set) (10) to center rail (6), using JCBC Bolt M6 X 50MM (E) and M4 Allen Key Long Ball Head (B). Fully tighten.

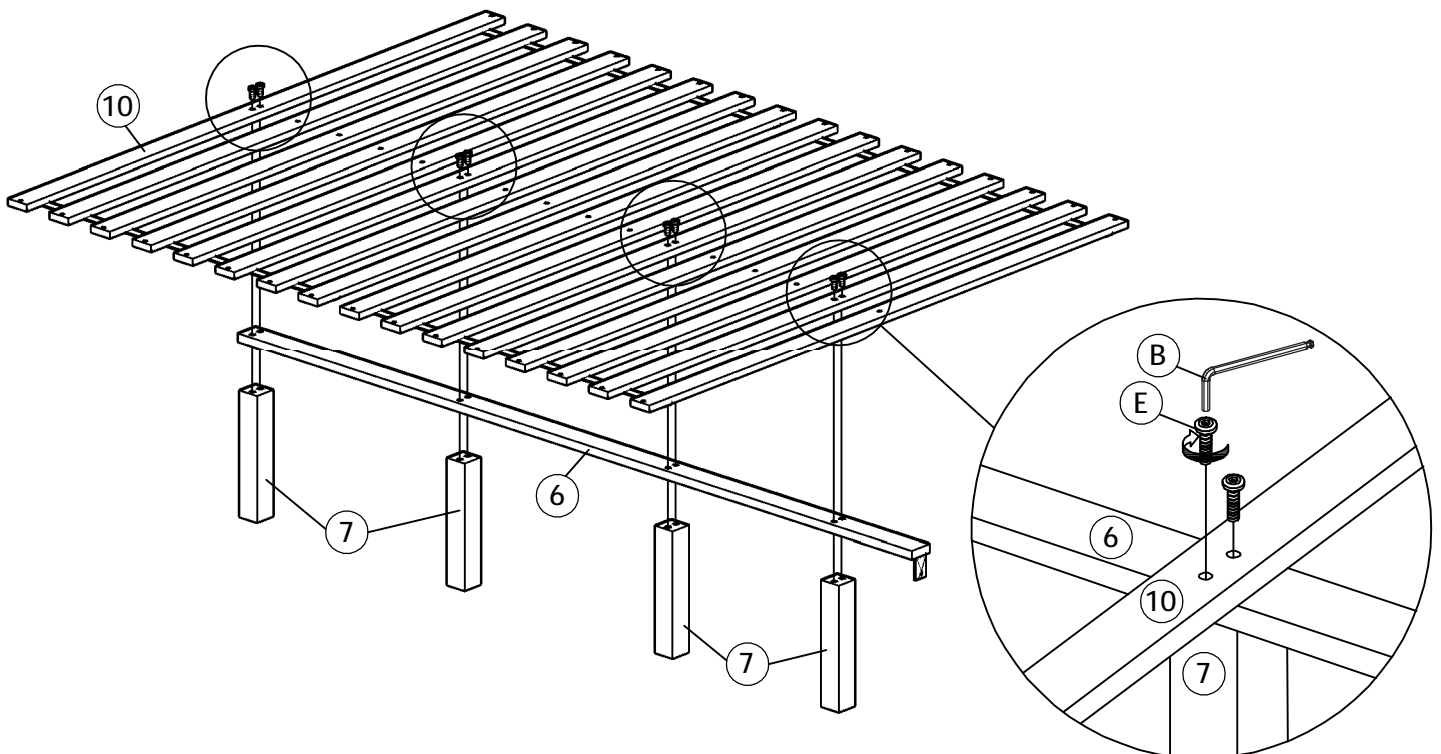

- 5** Attach assembled slats x8 (2 Set) (10) to side rail (5) and footboard (4), using Wood Screw M3.5 X 16MM (I) and Phillips Head Screwdriver (Not Included). Fully tighten.

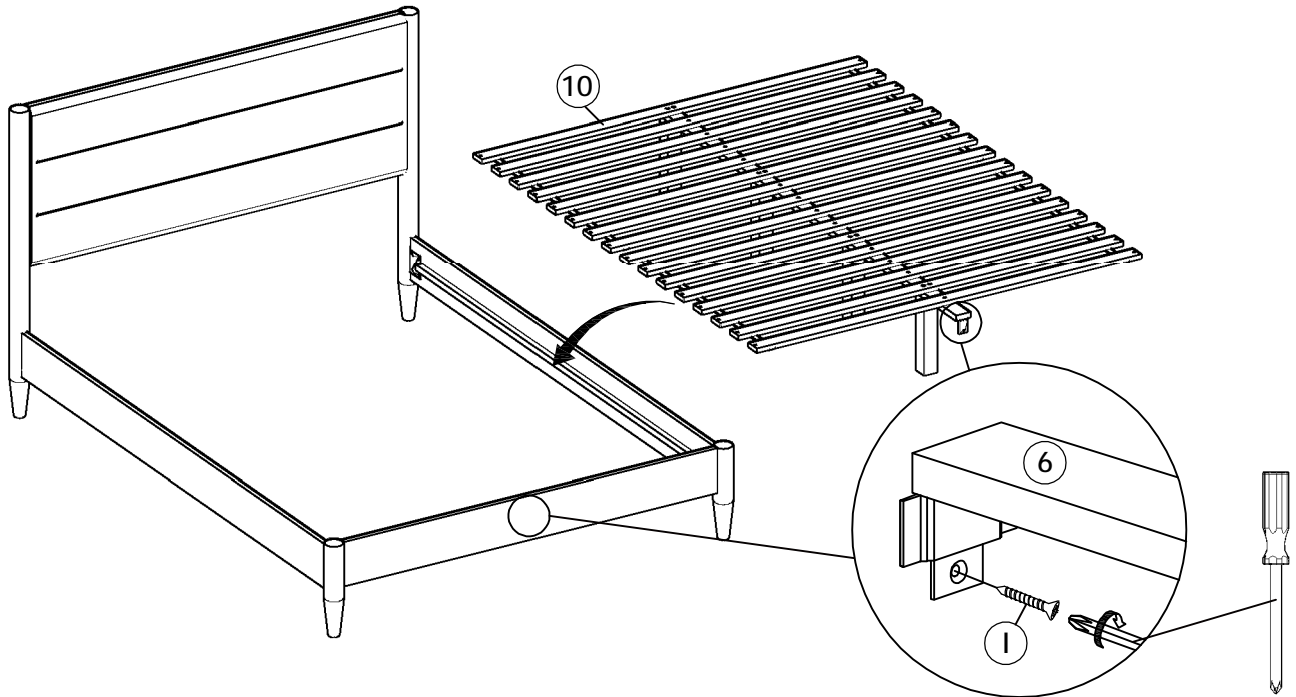

- 6** Attach assembled slats x8 (2 Set) (10) to side rail (5), using Wood Screw M4 X 30MM (J) and Phillips Head Screwdriver (Not Included). Fully tighten.

Note: Please fully tighten the four side screws that shown in below circled, then fully tighten the others screws.

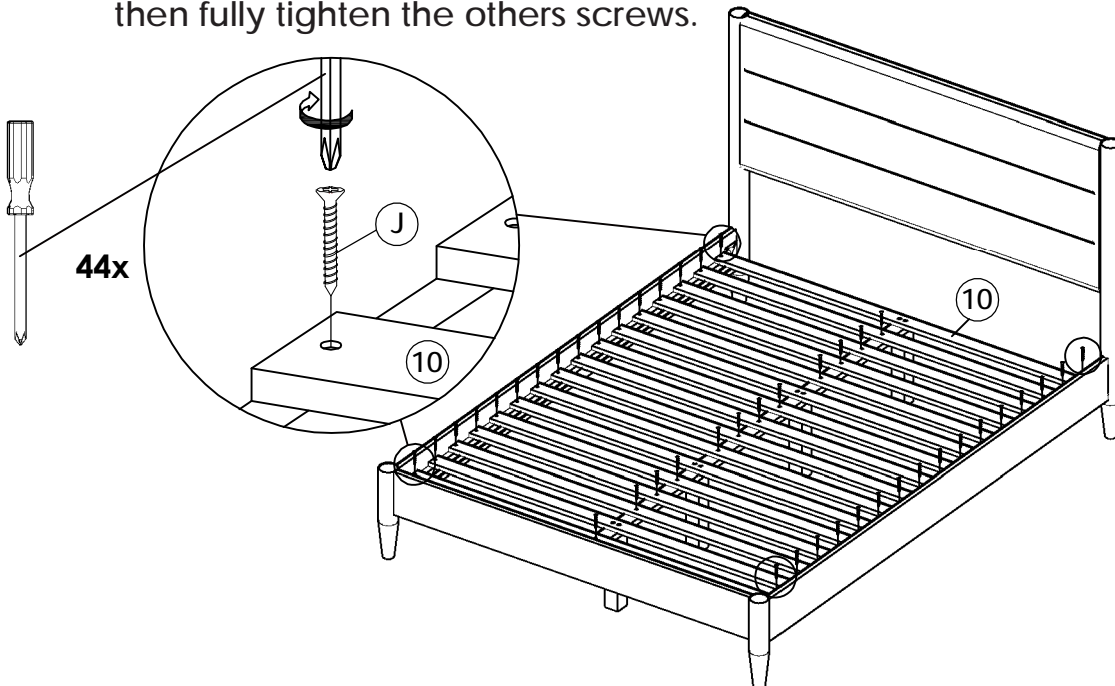

7 Assembly Completed. Enjoy.

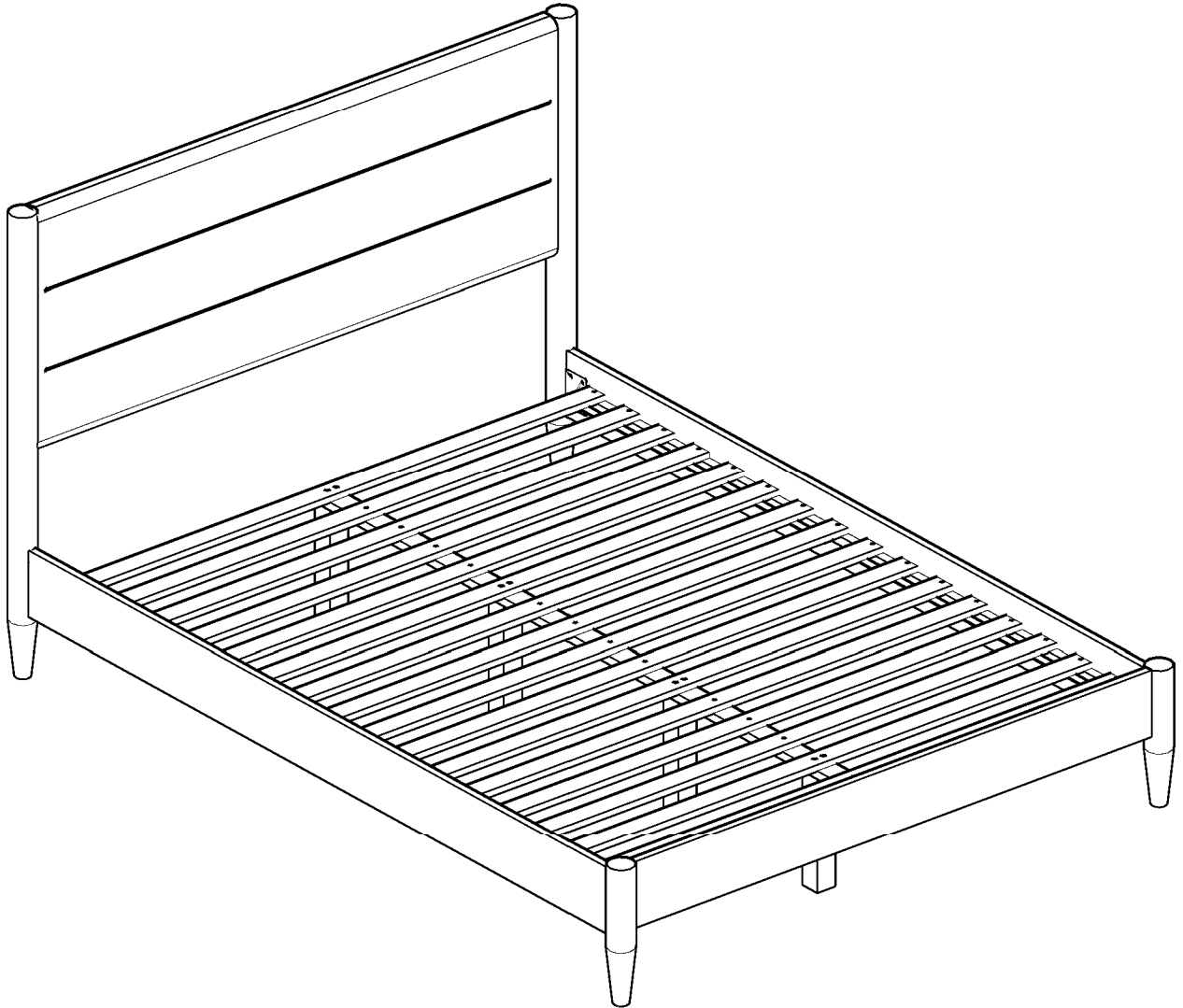

Design Exquisite Furniture For Your Home

PRODUCT WARRANTY

- 1-year limited on cover against splitting, peeling, and/or tearing.
- 1-year limited on internal and external frame structure.

Contact us:

We make all efforts to guarantee that the products you receive are in excellent condition. If there are any parts missing or damaged, the Customer Service Team will be happy to provide free replacements for you. We have professional warehouses where the current inventory of parts is enough so that they will arrive in your hands as fast as possible.

Assistance with assembly or product details is available; don't hesitate to get in touch with us to get priority service.
Our E-mail address: CS.furniture@outlook.com.



CS.furniture@outlook.com