

P72956 Assembly Manual

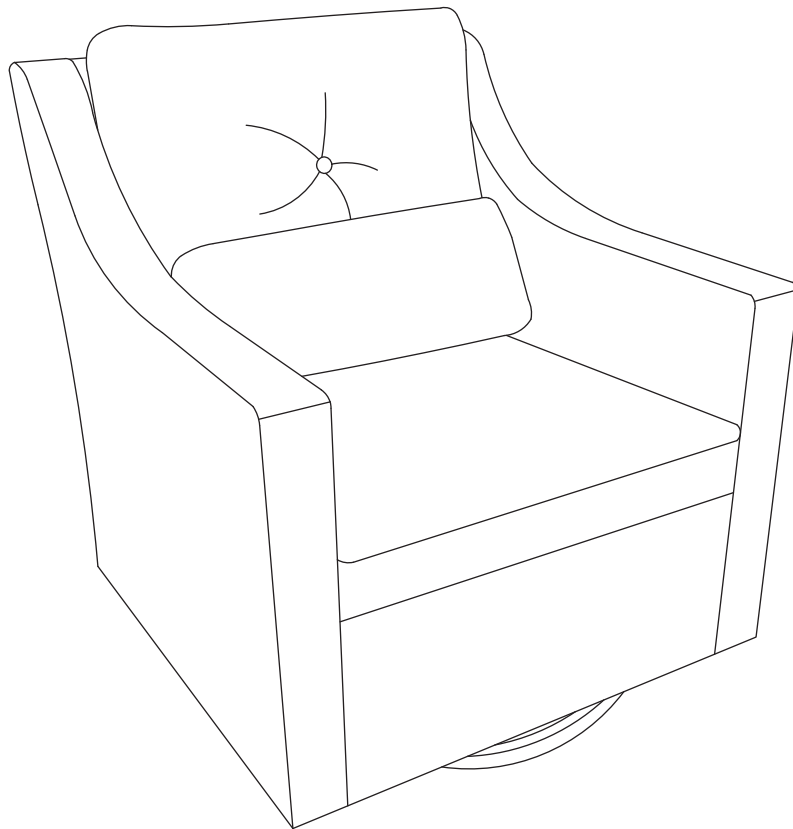



Swivel Glider Patio Chair





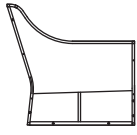
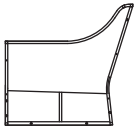
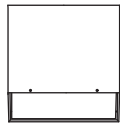
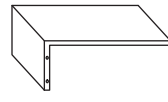
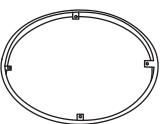
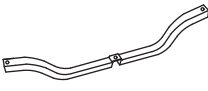
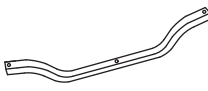

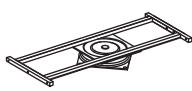
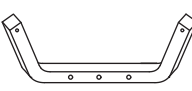
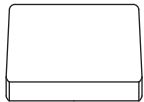

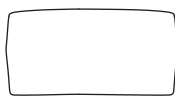



 **CAUTION**

THIS ASSEMBLY MANUAL CONTAINS IMPORTANT SAFETY INFORMATION.
PLEASE READ AND KEEP FOR FUTURE REFERENCE.

Components:

A×1  Right Arm	B×1  Left Arm	C×1  Back Panel	D×1  Seat Panel
E×1  Metal Ring	F×1  Metal Rod	G×1  Metal Rod	H×2  Connecting Rod
I×1  Inner Frame	J×2  Metal Rod	K×1  Seat Cushion	L×1  Back Cushion
M×1  Lumbar Pillow			

Hardware Pack:

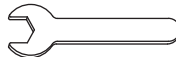
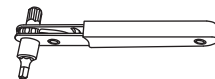
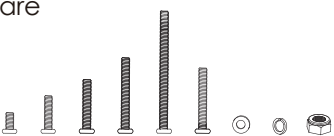
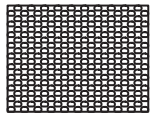
H1x5  Bolts (M6 x 15mm)	H2x10  Bolts (M6 x 40mm)	H3x6  Bolts (M6 x 45mm)	H4x6  Bolts (M6 x 55mm)
H5x2  Bolts (M6 x 95mm)	H6x4  Bolts (M6 x 50mm)	H7x43  Flat Washers (M6)	H8x18  Spring Washers (M6)
H9x18  Nuts (M6)	H10x1  Allen Wrench (4#)	H11x1  Open-Ended Wrench (M6)	H12x1  Ratchet Wrench (M6)
Extra Hardware 	Nx1  Non-Slip Mat (20'' x 20'')		

Before you begin:

1. Check if you have received all parts using the diagram on this page. Do not start the assembly process until all parts are present. If you have not received all parts or received wrong or damaged ones, please contact our customer service and we will get back to you.
2. Do not discard any of the packaging until you are certain that you have all the necessary parts for the assembly.
- 3. Proper assembly of this item requires two (2) people.**

- 1 Open the vacuum-packed bags containing the Seat Cushion (K), Back Cushion (L), and Lumbar Pillow (M).

Note: Do NOT use sharp tools such as knives or scissors to open these bags as it could potentially damage the cushions. Please use your hands to gently pull the bags apart.

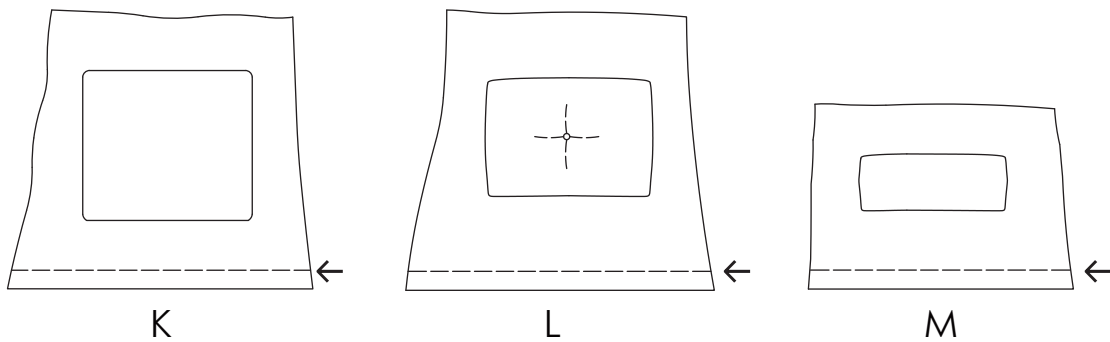

- 2 Please allow up to 48 hours for the cushions to return to the original thickness. For Back Cushion (L) and Lumbar Pillow (M), fluff the cushions as indicated below to help them return to the original thicknesses.

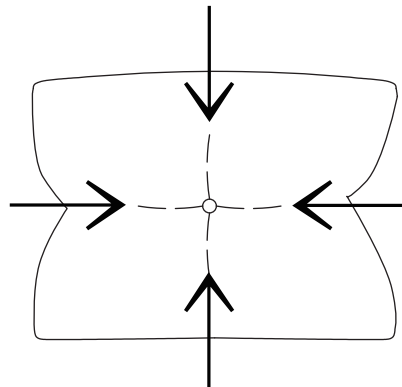

- 3 Please remove 2 pieces of Metal Rods (J) from Right Arm (A). Please remove Metal Rod (F), Metal Rod (G), and 2 pieces of Connecting Rods (H) from Left Arm (B).

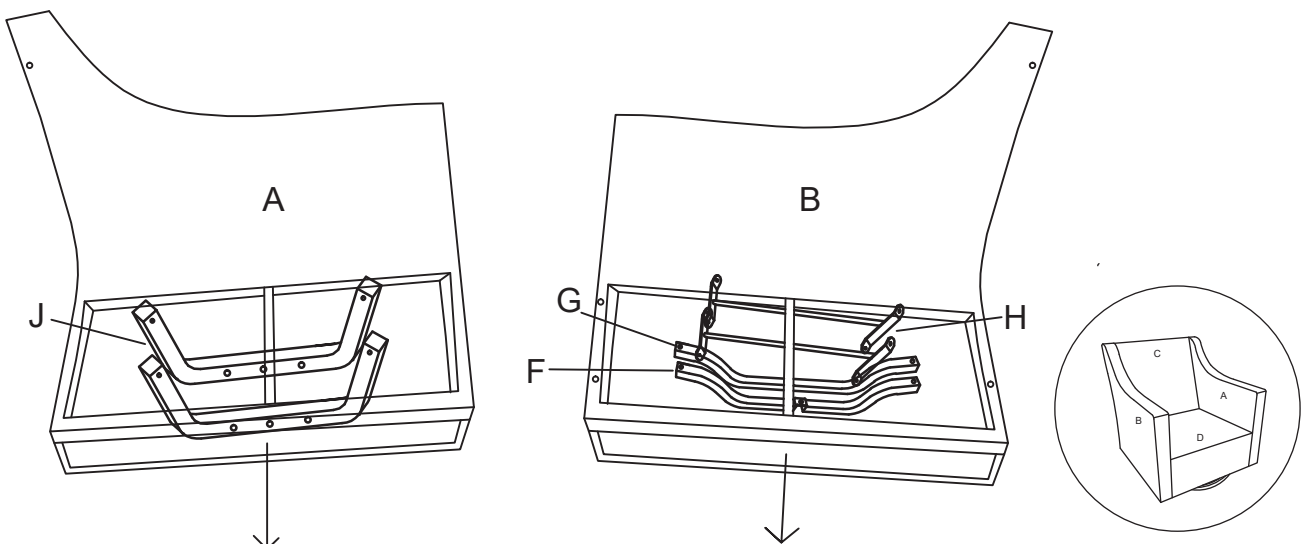

- 4** Place the Right Arm (A) flat on the floor. Attach Back Panel (C) to Right Arm (A), using Bolts (H2), Flat Washers (H7), and Allen Wrench (H10). Do NOT fully tighten yet.

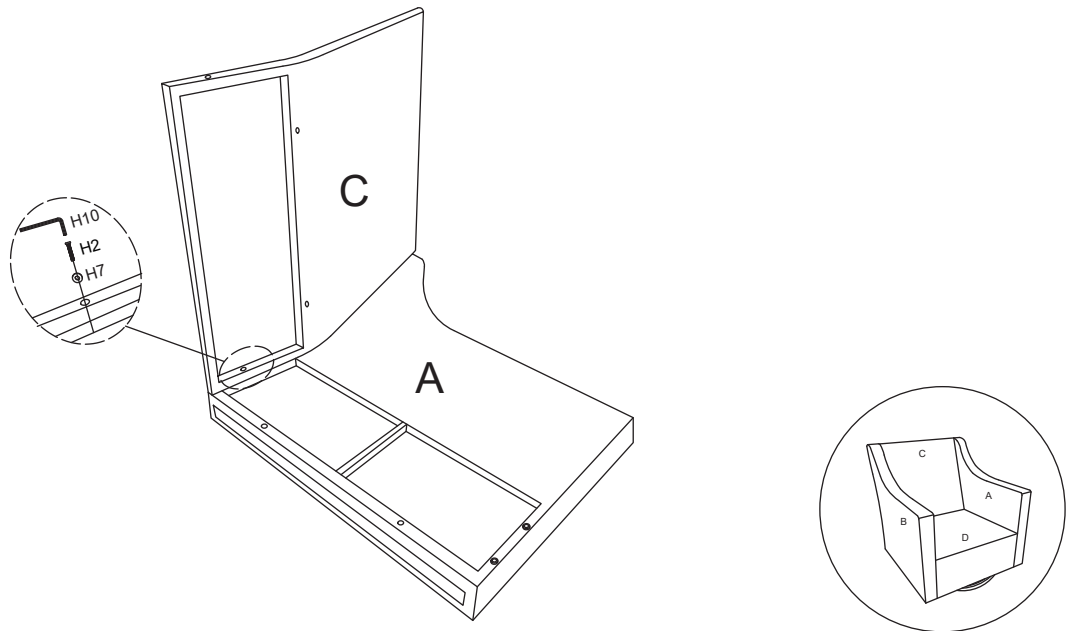

- 5** First, attach the front side of Seat Panel (D) to Right Arm (A), using Bolts (H2), Flat Washers (H7), and Allen Wrench (H10). **Do NOT fully tighten yet.** Then, attach the back side of Seat Panel (D) to Back Panel (C), using Bolts (H3), Flat Washers (H7), and Allen Wrench (H10). **Do NOT fully tighten yet.**

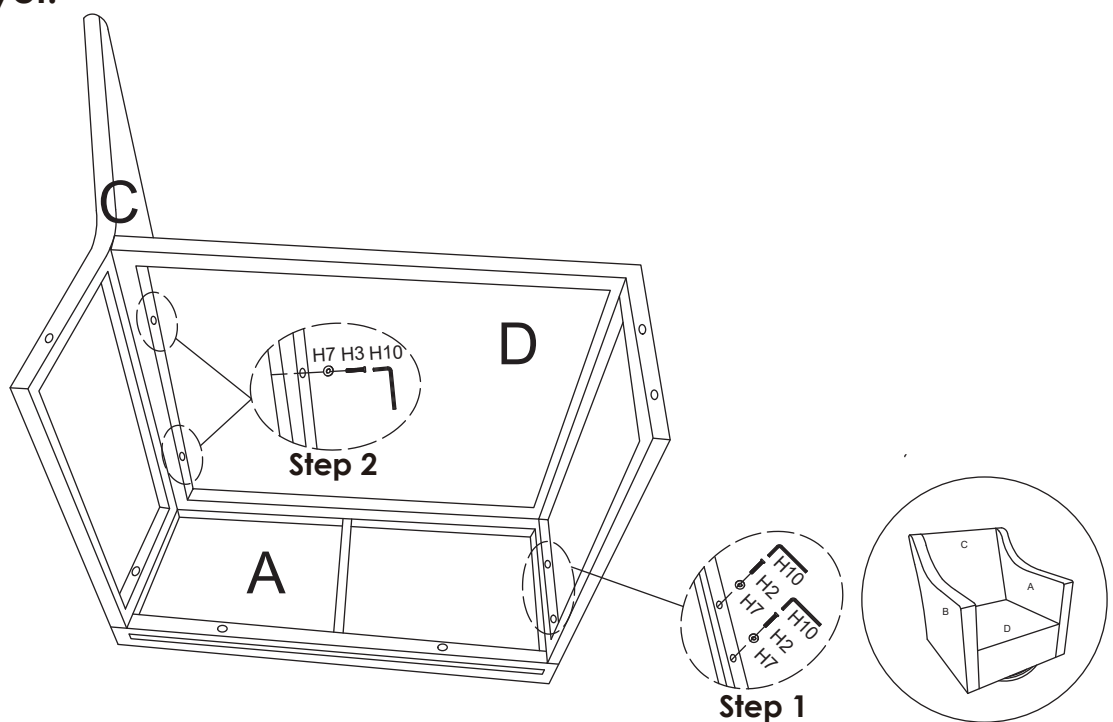

- 6** Place the chair upright. Attach Right Arm (A) to Back Panel (C), using Bolts (H5), Flat Washers (H7), and Allen Wrench (H10). **Do NOT fully tighten yet.**

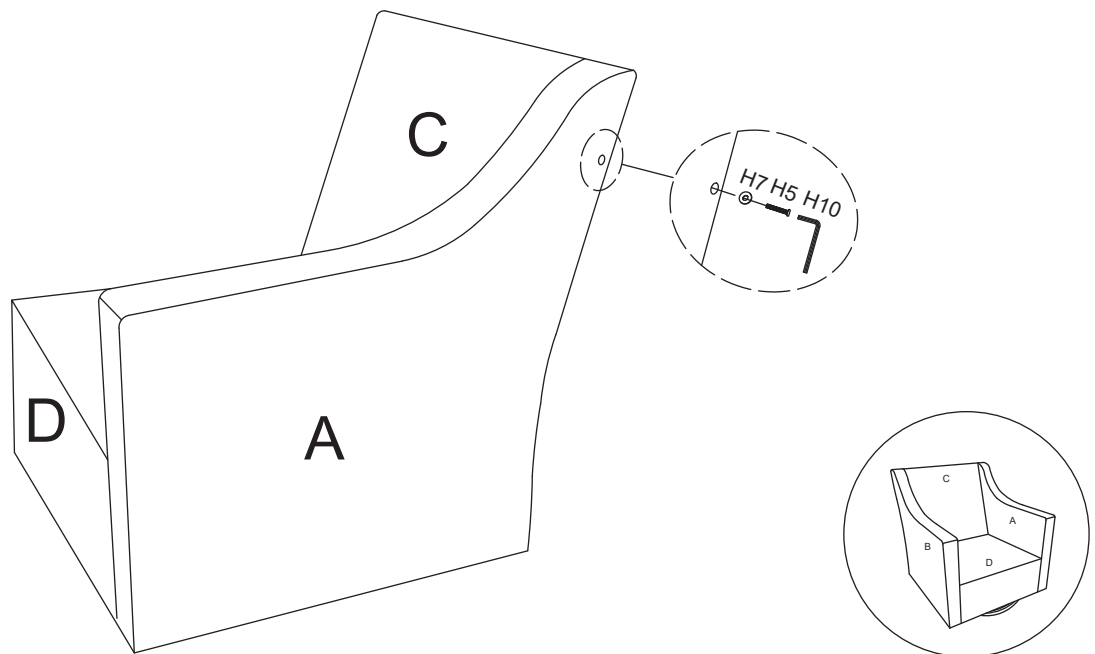

- 7** Place the Left Arm (B) flat on the floor. Attach the front side of Seat Panel (D) to Left Arm (B), using Bolts (H2), Flat Washers (H7), and Allen Wrench (H10). **Do NOT fully tighten yet.** Attach Back Panel (C) to Left Arm (B), using Bolts (H2), Flat Washers (H7), and Allen Wrench (H10). **Do NOT fully tighten yet.**

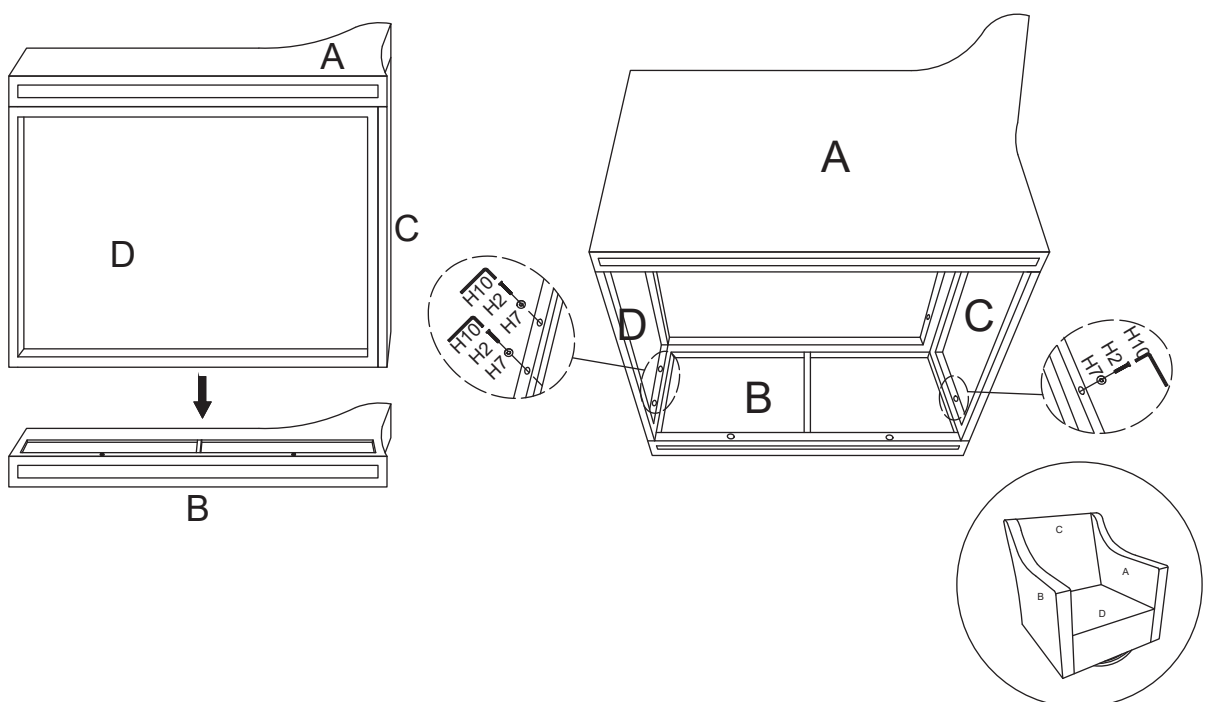

- 8** Place the chair upright. Attach Left Arm (B) to Back Panel (C), using Bolts (H5), Flat Washers (H7), and Allen Wrench (H10). **Do NOT fully tighten yet.**

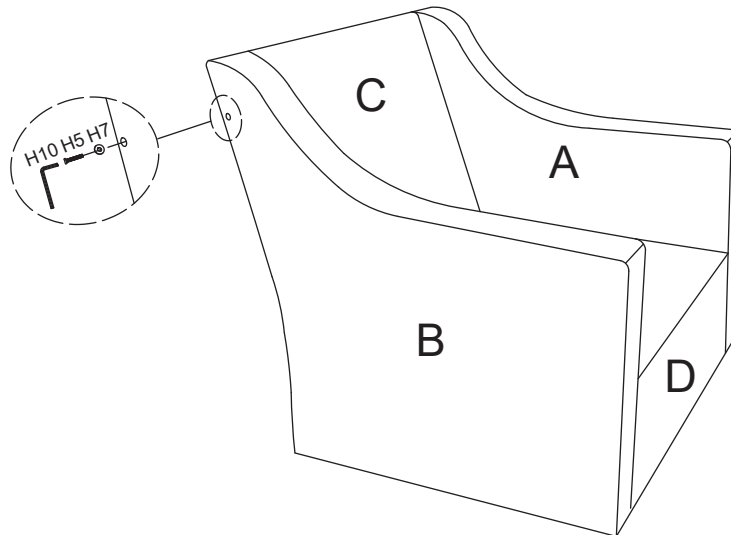

- 9** Set the button on Ratchet Wrench (H12) at "-". Use Ratchet Wrench (H12) to fully tighten all bolts in Step 4, 5, 6, 7, and 8.

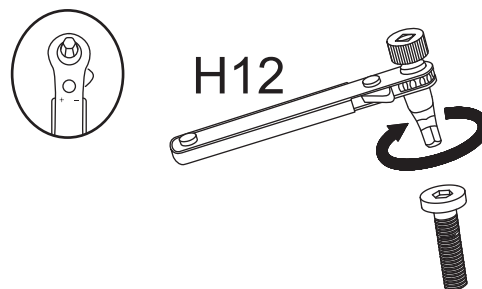

- 10** Attach Metal Rods (J) to Inner Frame (I), using Bolts (H4), Flat Washers (H7), Spring Washers (H8), Nuts (H9), Allen Wrench (H10), and Open-Ended Wrench (H11). **Loosely** attach the bolts one by one. **Do not fully tighten.** After all **six (6)** bolts are attached, use the Open-Ended Wrench (H11) to hold the Nuts (H9) steady, then use the Allen Wrench (H10) to **fully tighten** all Bolts (H4).

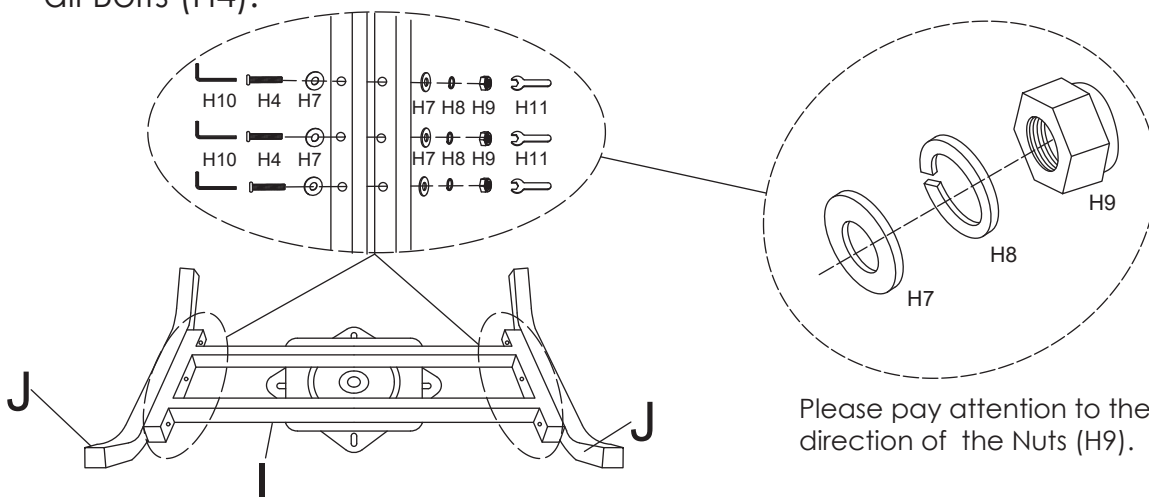

- 11** Attach Connecting Rods (H) to the assembled part in previous step, using Bolts (H3), Flat Washers (H7), Spring Washers (H8), Nuts (H9), Allen Wrench (H10), and Open-Ended Wrench (H11). Use the Open-Ended Wrench (H11) to hold the Nuts (H9) steady, use the Allen Wrench (H10) to tighten the Bolts (H3). **Fully tighten.**

Please pay attention to the direction of the Nuts (H9).

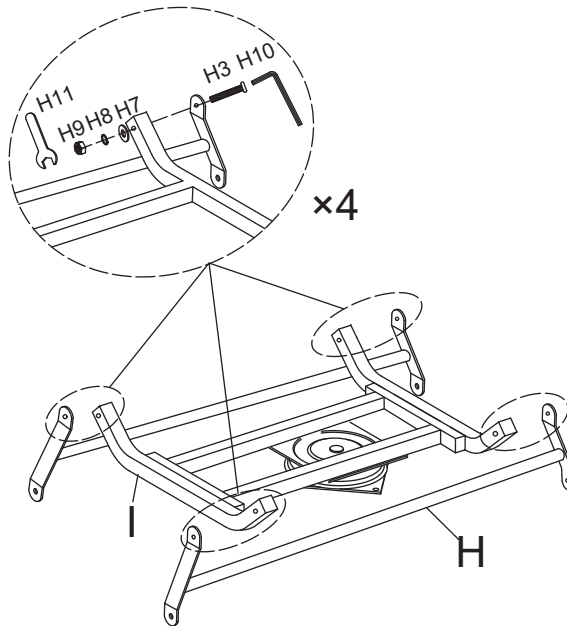

- 12** Attach the assembled part in previous step to the chair, using Bolts (H6), Flat Washers (H7), Spring Washers (H8), Nuts (H9), Allen Wrench (H10), and Open-Ended Wrench (H11). Use the Open-Ended Wrench (H11) to hold the Nuts (H9) steady, then use the Allen Wrench (H10) to tighten the Bolts (H6). **Fully tighten.**

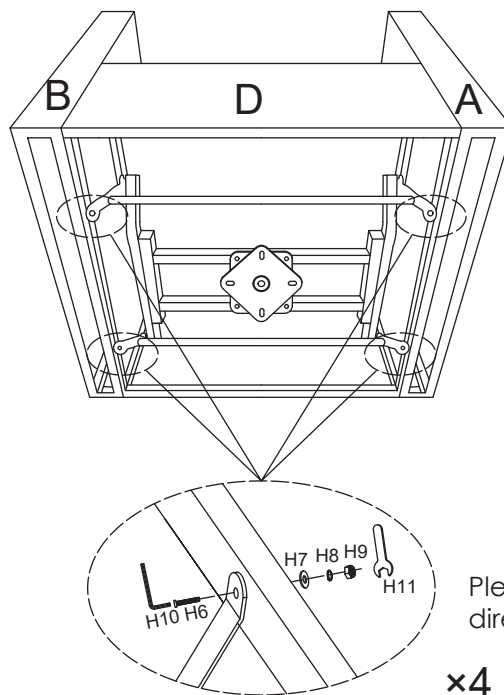

Please pay attention to the direction of the Nuts (H9).

- 13** Connect Metal Rod (F) and Metal Rod (G) together, using Bolts (H1), Flat Washers (H7), and Allen Wrench (H10). **Do not fully tighten yet.** Then, attach Metal Rod (F) and Metal Rod (G) to Metal Ring (E). **Loosely** attach the Bolts (H1) one by one and keep them loose. **Do not fully tighten.** After all 5 bolts are attached, **fully tighten** all bolts.

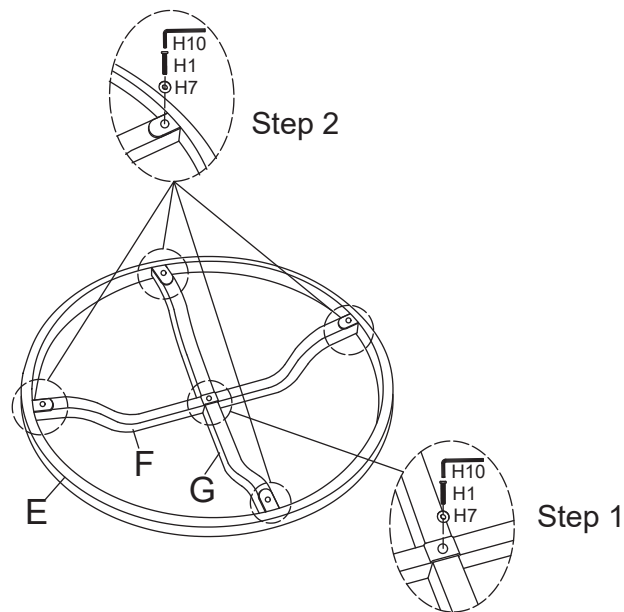

- 14** Attach the assembled metal base to the swivel plate, using Bolts (H2), Flat Washers (H7), Spring Washers (H8), Nuts (H9), Allen Wrench (H10), and Open-Ended Wrench (H11). Use the Open-Ended Wrench (H11) to hold the Nuts (H9) steady, then use the Allen Wrench (H10) to tighten the Bolts (H2). **Fully tighten.**

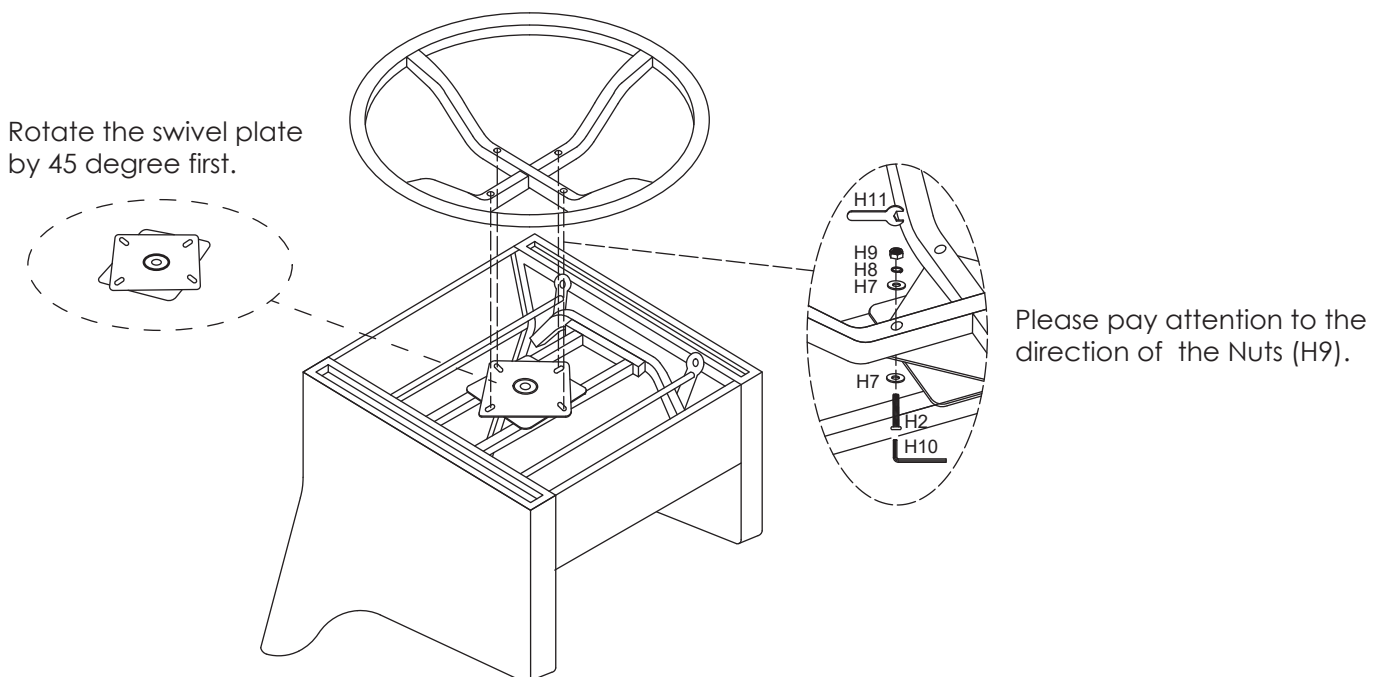

- 15** Flip chair onto its base. Place Non-Slip Mat (N) on the Seat.

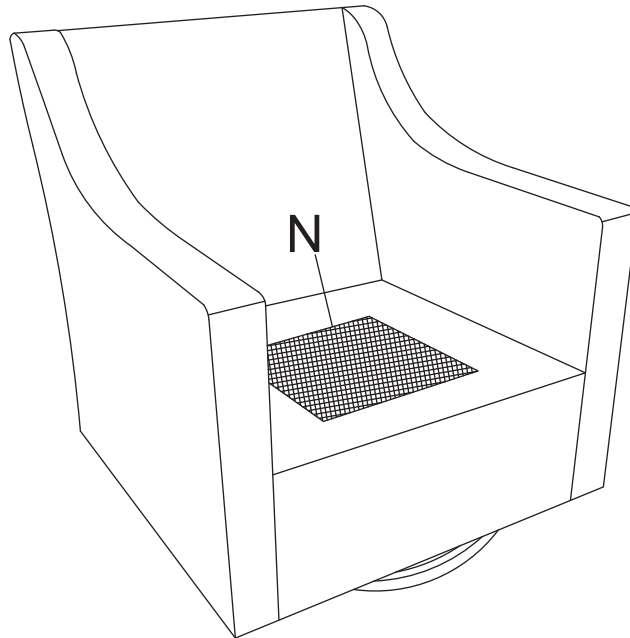

- 16** Place Seat Cushion (K), Back Cushion (L), and Lumbar Pillow (M) on the chair. Assembly complete. Enjoy.

